

Összeszerelési útmutató

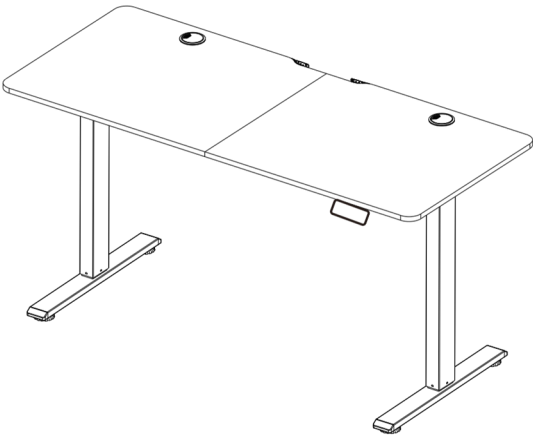

Tartozékok

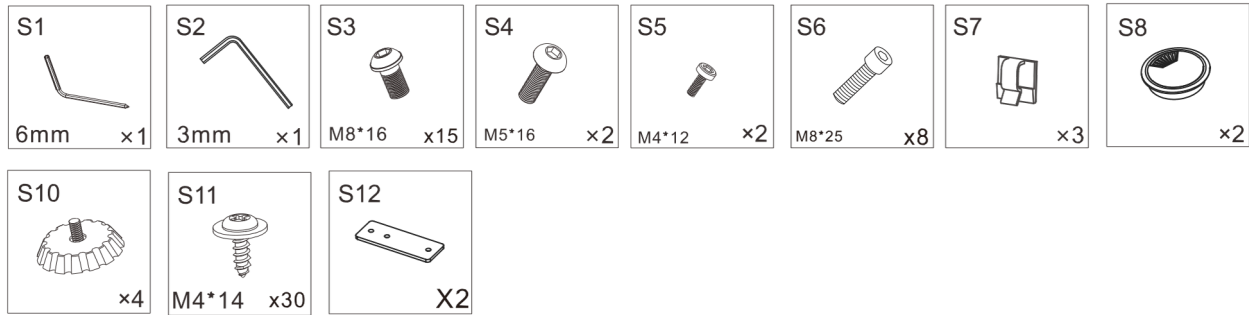

Alkatrészek

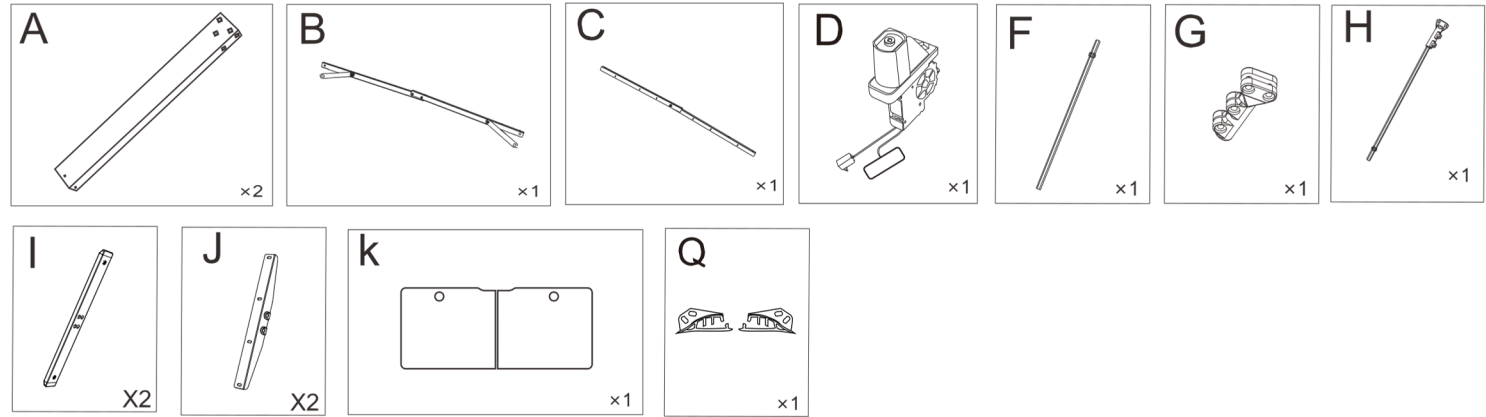

1

S3 M8*16 x4
S1 6mm x1

S3*2

S3*2

2

A*2
B

S3x2

S3x2

S3 M8*16 x4
S1 6mm x1

3

C

S3x2

Győződjön meg róla, hogy az elülső címkék ugyanabba az irányba néznek.

S3 M8*16 x2
S1 6mm x1

4

F
D
G

D
F
G

S3
2. lépés

S3 M8*16 x1
S1 6mm x1

1. lépés

5

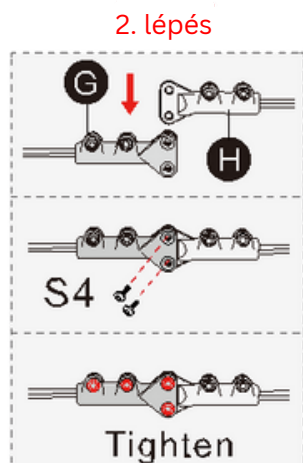
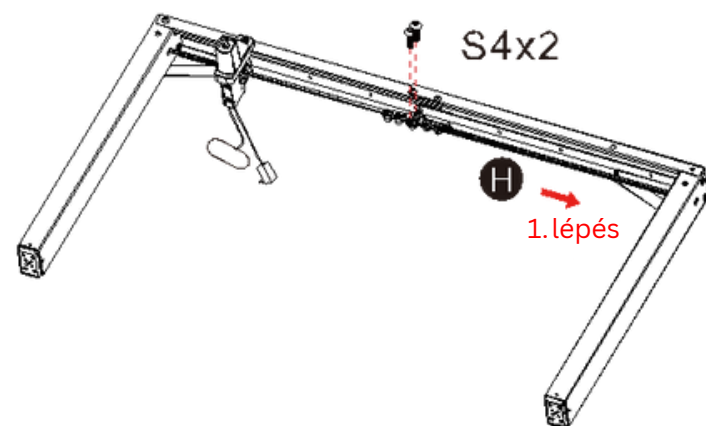
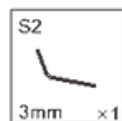
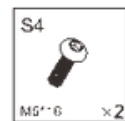
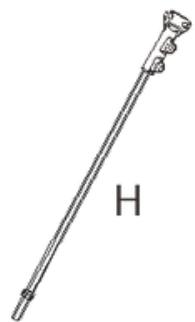

8



k



Q

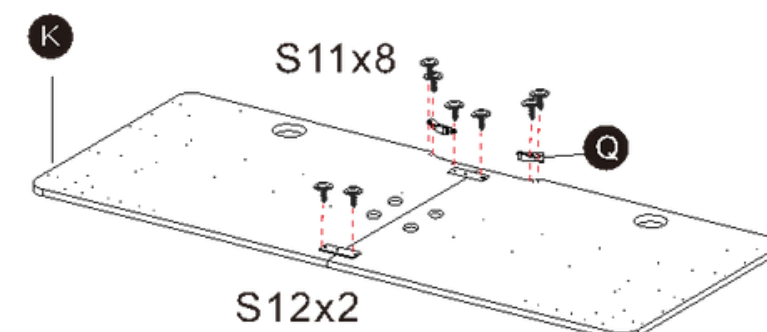
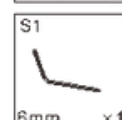
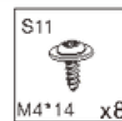

1. Kérjük, győződjön meg róla, hogy a két tábla egy vonalban van és hézagmentes.
2. majd húzza meg a csavarokat

6

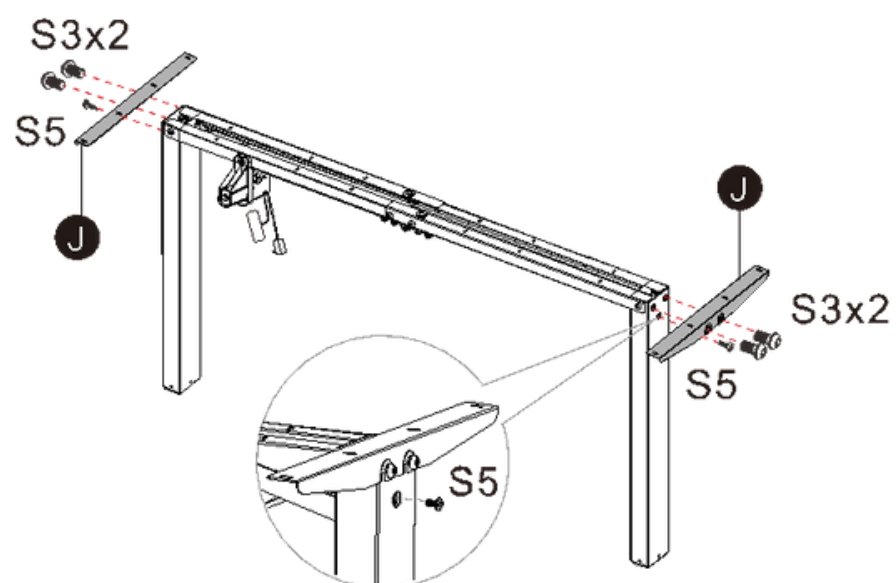
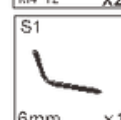
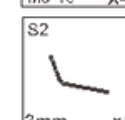
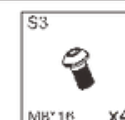
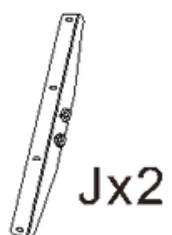

9

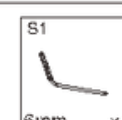
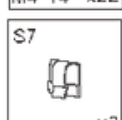
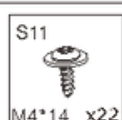
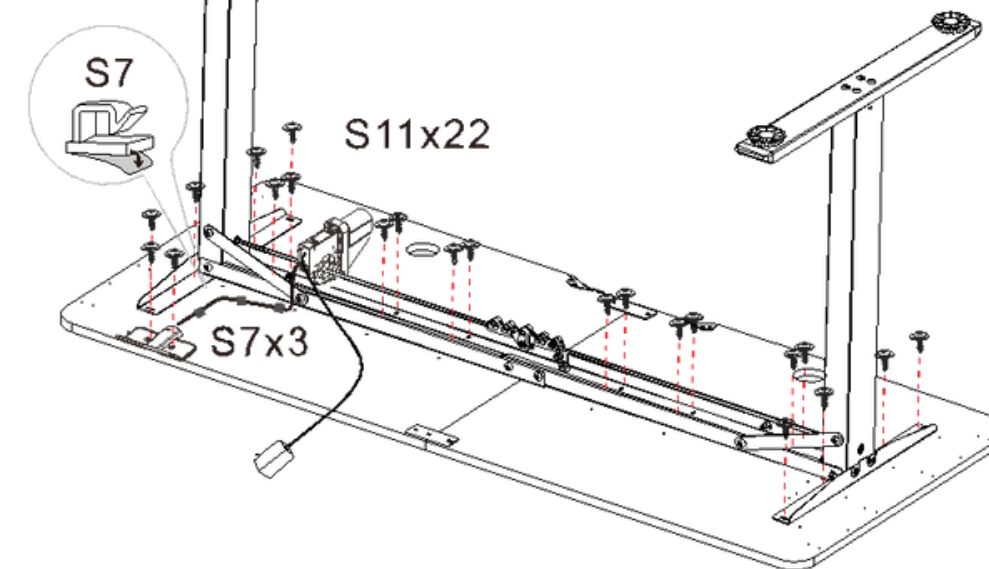

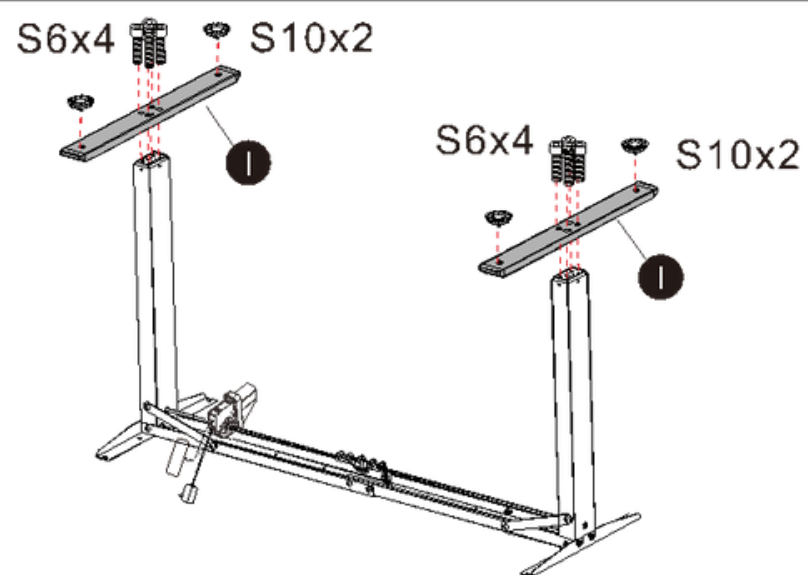
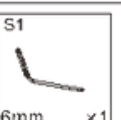
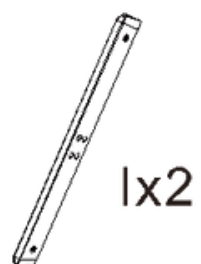

7

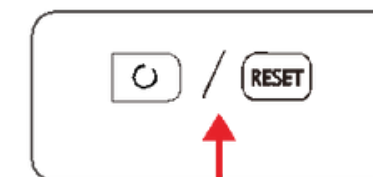
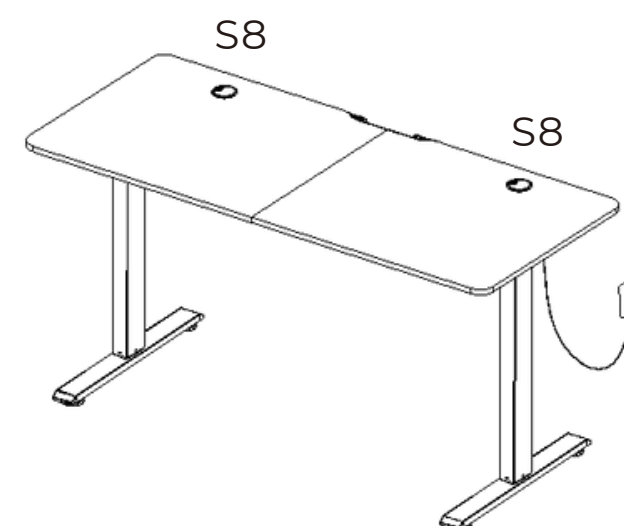

Ügyeljen arra, hogy az asztallábak függőlegesen álljanak az összekötő rúdhoz. És ezután húzza meg az összes csavart.

10



Az asztal összeszerelése után nyomja meg a  gombot az indításhoz.

Az asztal automatikusan a legalacsonyabb pontra esik, 3 másodpercig ott marad, majd a legmagasabb pontra emelkedik, és végül visszatér a kiindulási helyzetbe - sikeresen üzembe helyezte az asztalt.